

Lucalox™ PSL

Lucalox™ PSL Tubular Clear 230V 250W, 400W, 600W and 750W
Lucalox™ PSL Tubular Clear 400V 600W and 750W

DATASHEET

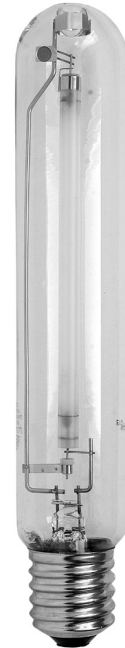

Superb performance and high reliability

- GE's advanced sodium resistant ceramic helps eliminate early failures to give a rated service life of up to 12,000 hours for the Lucalox™ PSL products.
- In order to achieve maximum performance, GE recommends lamp replacement when the rated service life is reached.
- The lamp uses extra rugged monolithic arctubes equipped with GE Reliable Starting Technology which provides continuous high performance.

High Xenon-Fill gas delivers:

- Extra light and PAR (Photosynthetically Active Radiation) output.
- More resistance to mains voltage fluctuations.

Zirconium gettering system gives:

- Improved PAR maintenance that drives constant and uniform plant growth.

Top Marking

- With the increased use of 400V systems, these lamps will be clearly marked with the voltage and wattage on the top of the lamp to ensure correct installation.

The diameter of the frame wire in the lamp has been minimised to reduce shading in the installation without affecting the robustness of the lamp.

Basic data

Product description of Standard Pack	LU250W/PSL/T/E40	LU400W/PSL/T/E40	LU600W/PSL/T/E40
Product description of Bulk Pack	N/A	LU400W/PSL/T/E40/Bulk	LU600W/PSL/T/E40/Bulk
Standard Product Code	88665	17106	17107
Bulk Product Code	N/A	44304	44305
Nominal Wattage [W]	250	400	600
Rated Wattage [W]	270	411	605
Lamp voltage [V]	115	105	115
Lamp current [A]	2,71	4,42	5,88
Cap	E40	E40	E40
Rated Lumen [lm] *	33500	56000	87000
Rated Luminous Efficacy [lm/W]	124	136	144
Rated PAR [$\mu\text{mol}/\text{sec}$] *	415	650	1000
Mercury Content [mg]	23.2	19.2	21.1
Rated life [h] **	12,000	12,000	12,000
CCT [K]	2100	2100	2100
Colour Rendering Index [Ra]	22	22	22
Ambient Temperature	25	25	25
Bulb	Hard	Hard	Hard
Mass Weight [g]	160	210	220
Operating Position	Universal	Universal	Universal



Product description of Standard Pack	LU750W/PSL/T/E40	LU400V/600W/PSL/T/E40/EL	LU400V/750W/PSL/T/2/E40/EL 1/12
Product description of Bulk Pack	LU750W/PSL/T/E40/Bulk	LU400V/600W/PSL/T/E40/EL BULK	LU400V/750W/PSL/T/2/E40 / EL BULK 1/63
Standard Product Code	17108	63919	43438
Bulk Product Code	44306	63922	43437
Nominal Wattage [W]	750	600	750
Rated Wattage [W]	720	616	760
Lamp Voltage [V]	110	200	205
Lamp Current [A]	7,26	3,57	4,30
Cap	E40	E40	E40
Rated Lumen [lm] *	105000	84000	10300
Rated Luminous Efficacy [lm/W]	146	136	136
Rated PAR [$\mu\text{mol}/\text{sec}$] *	1200	1069	1310
Mercury Content [mg]	21.1	21.9	24.7
Rated Life (h) **	4800	12,000	12,000
CCT [K]	2100	2100	2100
Colour Rendering Index [Ra]	22	22	22
Ambient Temperature	25	25	25
Bulb	Hard	Hard	Hard
Mass Weight [g]	230	220	230
Operating Position	Universal	Universal	Universal

* Rated PAR and Lumen values are referring to light output measurement of 100h aged bare lamp performed in Ulbricht sphere on rated lamp power
** Rated lamp life is defined at 90% average lamp survival rate.

Dimensions

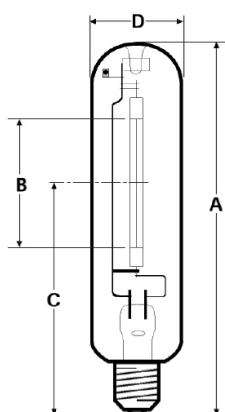

Figure 1.

Lamp data

Product Description	LU250W/ PSL/T/E40	LU400W/ PSL/T/E40	LU600W/ PSL/T/E40	LU750W/ PSL/T/E40	LU400V/600W/ PSL/T/E40/EL	LU400V/750W/ PSL/T/E40/EL
Standard Product Code	88665	17106	17107	17108	63919	43438
Bulk Product Code	N/A	44304	44305	44306	63922	43437
Nominal Wattage [W]	250	400	600	750	600	750
A Max. Length (mm)	260	292	292	291	292	293
B Arc Gap (mm)	67	87	117	115	124.5	143
C LCL (mm)	158	175	169	171	169	175
D [mm]	48	48	48	51	48	51

Lamp survival and PAR maintenance

Rated service lamp life & PAR maintenance is based on laboratory tests of a large number of representative lamps under controlled conditions, including operation at 3 hours per start on ballasts having specified electrical characteristics. Reliability is also tested in large scale field tests in greenhouses.

Initial PAR value refers to the lamp light output after 100-hours burning time. Due to variations in system and service conditions (in particular the burning cycle and the operating system), actual lamp performance may typically vary from the reference PAR ratings with a tolerance of 3%.

The survival of individual lamps or particular groups of lamps depends on system and service conditions (see below).

The following conditions can reduce average lamp life and lumen maintenance:

- frequent on/off switching
- high line voltage
- excessive vibration
- high ambient temperature within the fixture
- non-compatible ballast and ignitor characteristics

Typical average PAR maintenance

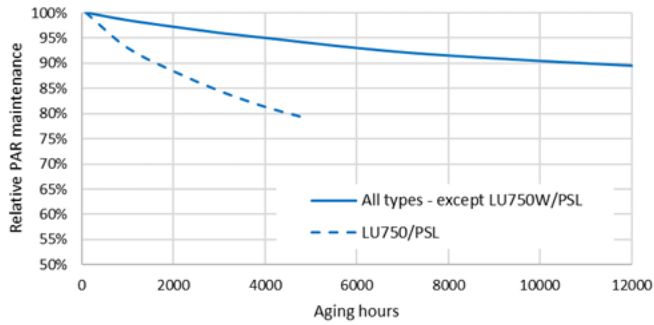

Typical average lamp survival

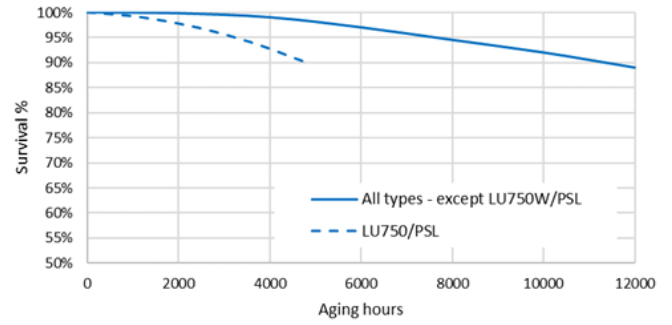

Rated service life

For cost-of-light calculations involving these lamps, it is suggested to replace both the 230V and the 400V type PSL lamps after 10,000 hours burning.

Spectral power distribution

Spectral power distribution – 230V type PSL lamps

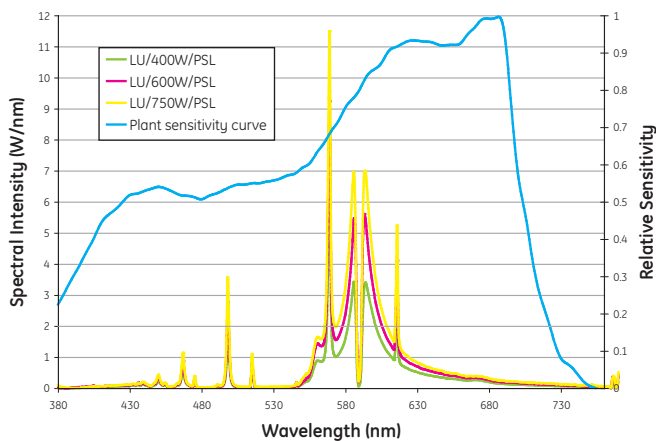

Spectral power distribution – 400V type PSL lamps

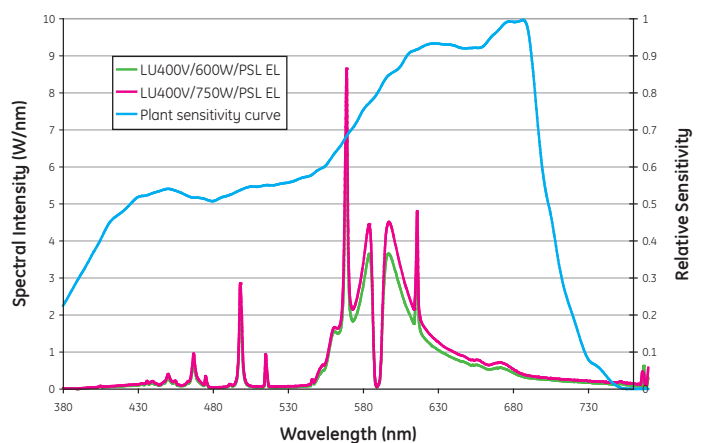

Run-up characteristics

The graph shows typical run-up characteristics for a LU600W/PSL lamp. The time needed for the light output to reach 90% of the final value is determined by the supply voltage and ballast design. Typical values are:

Watts	400	600	750
Run-Up (minutes)	5	4	3

Typical run-up characteristics

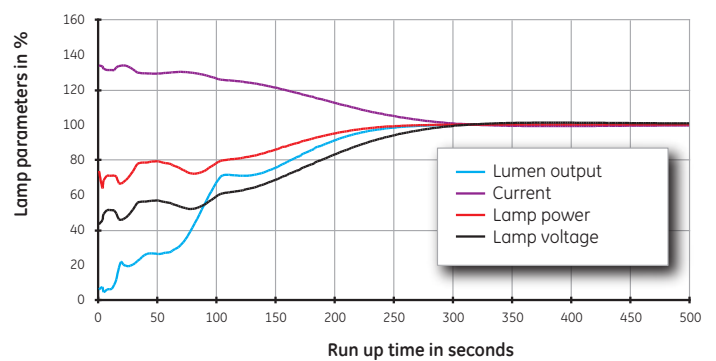

Hot restrike time

All ratings restrike within 5 minutes. This occurs when the lamp has cooled to a temperature at which the starting aid can re-establish the arc. The new solid state starting aid is integrally bonded to the arc tube for shorter restrike time, and improved reliability — no moving parts or welds.

Supply voltage

230V PSL lamps are suitable for supplies in the range 220V to 250V 50/60 Hz for appropriately rated series choke (reactor) ballasts. Supplies outside these ranges require a transformer (conventional, high reactance or CWA) to ensure correct lamp operation. Lamps start and operate at 10% below the rated supply voltage when the correct control gear is used. In order to maximize lamp survival and PAR maintenance, the supply voltage and ballast design voltage should be within $\pm 3\%$.

This may be achieved by measuring mean supply voltage at the installation and selecting ballasts with appropriate settings. Lamps should be used with gears rated to lamp nominal supply voltage.

Ballasts

It is essential to use a ballast appropriate to the supply voltage at the luminaire. Typical wiring diagrams for control circuits incorporating “Superimposed” or “Impulser” ignitor and choke (reactor) ballast are shown. Refer to actual choke and ignitor manufacturers’ data for terminal identification and wiring information.

Typical impulser ignitor circuit

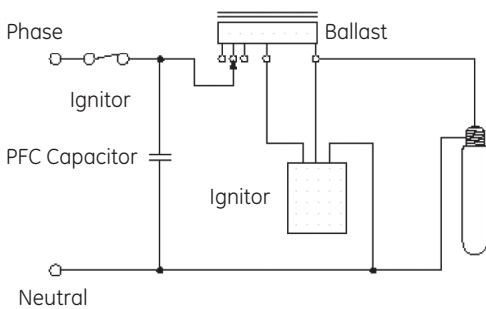

Typical superimposed ignitor circuit

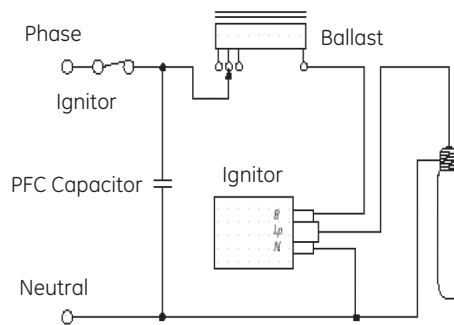

400V PSL lamps should be operated on GE approved electronic ballasts with adequate end of life protection only. See approved ballast list below:

Approved electronic ballast list :

- New Lighting NL-S 600/400 GN3B
- New Lighting NL-S 750/400 GN3B
- Philips Green Vision II 600W/P GP-SON 400V
- Nedap 400/750W
- Nedap 400/600W
- Philips Green Vision III 600W/P GP-SON 400V
- Philips Green Vision II 750W/P GP-SON 400V

Mains voltage variations – 230V PSL

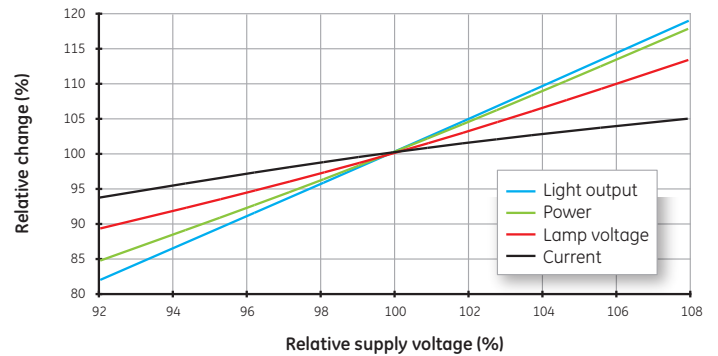

Guidance for luminaire manufacturers

Lamp operating temperature limits

Watts	250	400	600	750
Clear Tubular				
Max. Bulb Temperature	400 °C	400 °C	410 °C	410 °C
Max. Cap Temperature	250 °C	250 °C	250 °C	250 °C

Luminaire voltage rise

To maximize lamp life it is essential that luminaires are designed so that when lamps are enclosed lamp voltage rise does not exceed the following values:

Watts	250	400	600	750
Clear Tubular				
Voltage Rise (V)	12	12	12	12

Ballasts

To achieve correct lamp starting, performance and life, it is important that the lamp and ballast are compatible and suitably rated for the supply voltage at the luminaire.

Lucalox™ PSL lamps comply with IEC62035 (HID Lamp Safety) standards. Ballasts used to operate these lamps should comply with ballast standards IEC60922 & IEC60923 and incorporate adequate overload protective measures to ensure that safety is maintained under abnormal lamp end-of-life rectification conditions as prescribed by IEC62035 and draft changes to luminaire standard EN60598-1. Ballast thermal protection is recommended for providing adequate protection.

Ballast voltage adjustment — For series choke (reactor) ballasts a single additional tapping 10V (230V line voltage) above the rated supply voltage are recommended. This will ensure lamps are not over loaded due to excessive supply voltage.

PFC capacitors for choke (reactor) circuits

Power Factor Correction is advisable in order to minimise supply current and electricity costs. For 220-250V supplies, 250V nominal voltage rated capacitors with $\pm 10\%$ capacitance tolerance are recommended.

Watts	LU250W/PSL	LU400W/PSL	LU600W/PSL	LU750W/PSL
Ballast impedance (for 230V rated supply) (V/A)	63	40.9	29.7	24.2
PFC Capacitor [μ F]	30	50	60	60

Ignitors

Ignitors should comply with specifications IEC60926 and IEC60927 and have starting pulse characteristics as follows:

Watts	Min. Pulse Voltage [kV] ¹	Max. Pulse Voltage [kV] ²	Min. Pulse Width [kV] ³	Min. Pulse Repetition Rate ⁴
250	3.3	5.0	1.95	1 / cycle
400	3.3	5.0	1.95	1 / cycle
600	4.0	5.0	1.95	1 / cycle
750	3.3	5.0	1.95	1 / cycle

1. When Loaded with 100 pF min.
2. When Loaded with 20 pF max.

3. At 90 % peak voltage
4. Pulse Phase Angle: 60-90°el and/or 240-270° el

Timed ignitors

Use of a “timed” or “cut-out” ignitor is not a specific requirement, but it is a good optional safety feature for the installation. The timed period must be adequate to allow lamps to cool and restart when the supply is interrupted briefly (see “Hot re-strike time”). A period of 10 minutes continuous or intermittent operation is recommended before the ignitor is automatically switched off. Commercially available 10/11 minute timed ignitors are suitable.

Cable between ignitor and lamp

Cables connected between the lamp and a superimposed ignitor “Lp” terminal, or the ballast when using an impulser ignitor, must be rated at a minimum 50/60Hz voltage of 1000V. Mineral-insulated cables are not suitable for connecting the lamp to the control gear.

To achieve good starting superimposed ignitors must be adjacent to the luminaire. Cable capacitance of wiring between the ignitor “Lp” terminal and the lamp should not exceed 100pF (<1 metre length) when measured to adjacent earthed metal and/or other cables, unless otherwise stated by the ignitor manufacturer. When using impulser type ignitors, longer cable lengths between ballast and lamp are normally permissible. Limits for particular ignitors are available directly from the ignitor manufacturer.

Certificate



GE Lighting is constantly engaged in the global quality process. A statistical quality system designated SIX SIGMA is applied across the board in all areas of the company from manufacturing through to sales.

Application area



Horticulture

Caution



Special purpose lamps.
Not suitable for household illumination.

Safety warnings

The use of these products requires awareness of the following safety issues:

WARNING

Risk of electric shock

- Turn power off before inspection, installation or removal
- Do not use where directly exposed to water or outdoors without an enclosed luminaire.

Risk of fire

- Do not keep combustible materials near/below lamp operated in open luminaire.
- Use in luminaire rated for this product - see instructions
- Use fused or thermally protected ballast
- Operate all 400V PSL lamps on GE approved electronic ballasts with adequate end-of-life protection only compliant with IEC 62035.

Contains sodium – chemical burn risk

- Avoid skin contact with broken pieces

Unexpected lamp rupture may cause injury, fire, or property damage

- Do not exceed rated voltage, wattage
- Do not use where directly exposed to water or outdoors without an enclosed luminaire
- Do not use lamp if outer glass is scratched or broken
- Use only properly rated ballast
- Do not store flammable materials near/below lamp operated in open luminaire. While lamp breaking is extremely unlikely hot lamp parts may fall and cause property damage.
- Do not turn on lamp until fully installed

CAUTION

Risk of burn

- Allow lamp to cool before handling

Lamp may shatter and cause injury if broken

- Wear safety glasses and gloves when handling lamp
- Dispose of lamp in a closed container
- Do not use excessive force when installing lamp